

Basler Scout2

Area Scan Cameras

GiGE[®]
VISION

GEN<i>CAM



- VGA to 2 megapixels and up to 120 fps
- Selected high quality CCD and CMOS sensors
- Excellent price/performance ratio
- Gigabit Ethernet interface with PoE
- Enhanced color features

BASLER 
VISION TECHNOLOGIES

click. see. smile!

Specifications

Basler Scout2	Resolution (H x V pixels)	Sensor	Sensor Technology	Sensor Size (optical)	Pixel Size (µm)	Frame Rate	Power Consumption (typical)	Weight (typical)
s2A640-70gm/gc	659 x 494	Sony ICX424	Progressive scan CCD	1/3"	7.4 x 7.4	70	3 W	150 g
s2A640-74gm/gc*	659 x 494	Sony ICX414	Progressive scan CCD	1/2"	9.9 x 9.9	79	3 W	150 g
s2A640-120gm/gc*	659 x 494	Sony ICX618	Progressive scan CCD	1/4"	5.6 x 5.6	122	3.5 W	150 g
s2A750-60gm/gc*	752 x 480	Aptina MT9V022	Progressive scan CMOS	1/3"	6.0 x 6.0	64	3 W	150 g
s2A780-54gm/gc	782 x 582	Sony ICX415	Progressive scan CCD	1/2"	8.3 x 8.3	55	3 W	150 g
s2A1000-30gm/gc*	1034 x 779	Sony ICX204	Progressive scan CCD	1/3"	4.65 x 4.65	31	3 W	150 g
s2A1300-32gm/gc	1296 x 966	Sony ICX445	Progressive scan CCD	1/3"	3.75 x 3.75	32	3.5 W	150 g
s2A1390-17gm/gc	1392 x 1040	Sony ICX267	Progressive scan CCD	1/2"	4.65 x 4.65	17	3.5 W	150 g
s2A1400-17gm/gc	1392 x 1040	Sony ICX285	Progressive scan CCD	2/3"	6.45 x 6.45	17	3.5 W	160 g
s2A1400-30gm/gc*	1392 x 1040	Sony ICX285	Progressive scan CCD	2/3"	6.45 x 6.45	30	3.5 W	160 g
s2A1600-14gm/gc	1628 x 1236	Sony ICX274	Progressive scan CCD	1/1.8"	4.4 x 4.4	14	3.4 W	150 g
s2A1600-25gm/gc*	1628 x 1236	Sony ICX274	Progressive scan CCD	1/1.8"	4.4 x 4.4	25	3.4 W	150 g

Cameras will be available end of Q2/2011 * Available end of Q3/2011

Specifications Applicable For All scout2 Models:

Mono / Color	Mono / Color
Interface	Gigabit Ethernet (GigE Vision compatible)
Video Output Format	Mono 8:8 bits/pixel Mono 16:12 bits/pixel YUV 4:2:2:16 bits/pixel average YUV 4:2:2: (YUYV):16 bits/pixel average Raw 8:8 bits/pixel (R,G or B) Raw 16:12 bits/pixel (R,G or B) s2A750-60gm/gc (8 bits/pixel only)
Synchronization	Via external trigger, or free run
Exposure Control	Programmable via GigE Vision (camera API)
Housing Size (LxWxH)	73.7 mm x 44.0 mm x 29.0 mm (without lens adapter)
Housing Temperature	Up to 50°C
Lens Mount	C-mount
Digital I/O	2 opto-isolated input ports, 2 opto-isolated output ports
Power Requirements	Via Power over Ethernet (802.3af) or via Hirose 12-pin connector (12-24V, max. 10 meter cable lengths)
Conformity	CE, FCC, RoHS, IP 30, GigE Vision, GenICam
Software Driver	Basler pylon (Basler filter and performance driver)

Specifications are subject to change without prior notice.

TECHNICAL DETAILS

Dimensions (in mm)

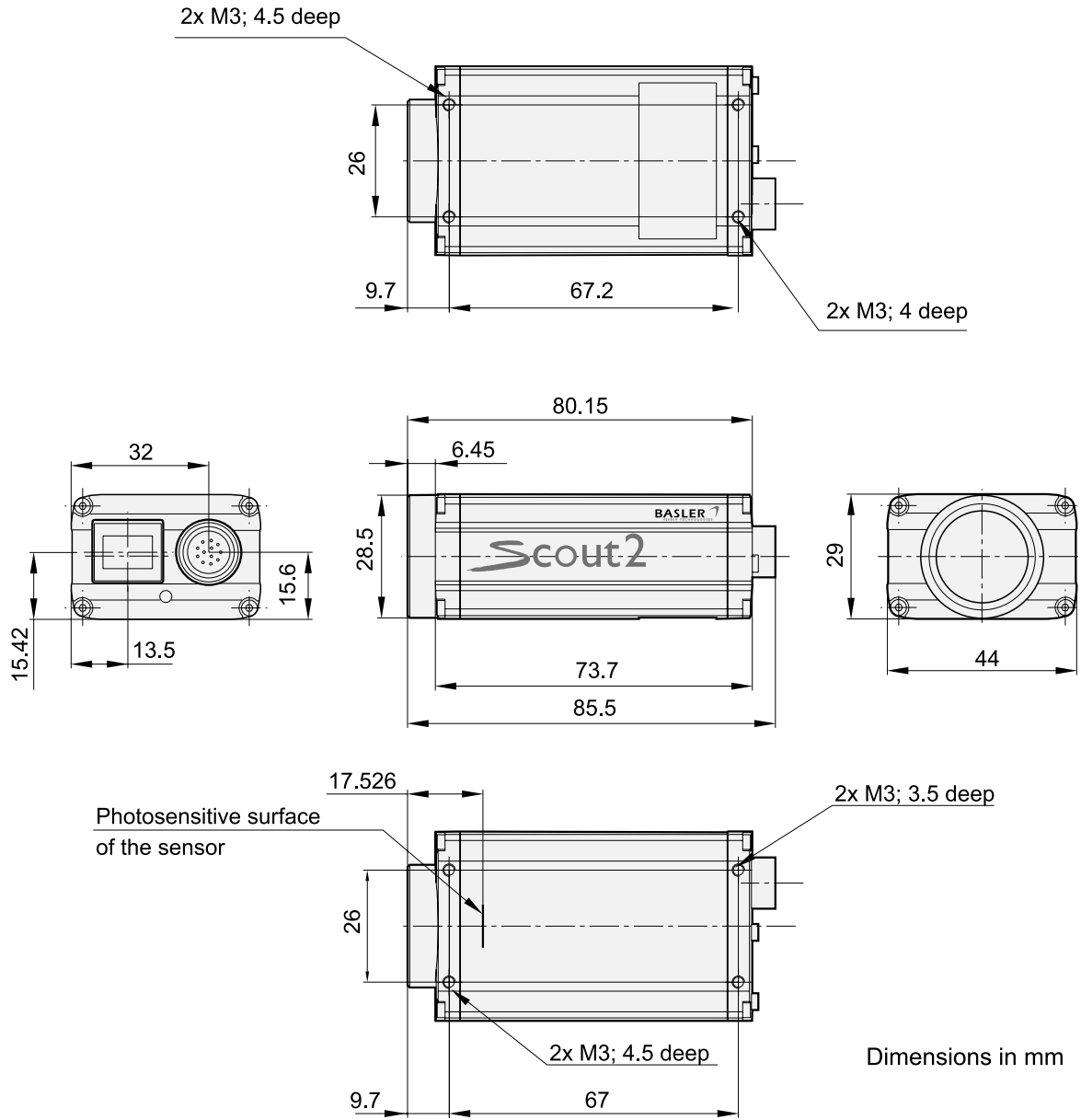

Basler pylon Driver Package

The pylon driver package is designed to work with all Basler cameras that have a FireWire or GigE Vision interface. You can select the interface technology that best fits your application or you can use both interface technologies simultaneously in your application. The pylon driver offers reliable, real-time image data transport into the memory of your PC with a very low CPU load.

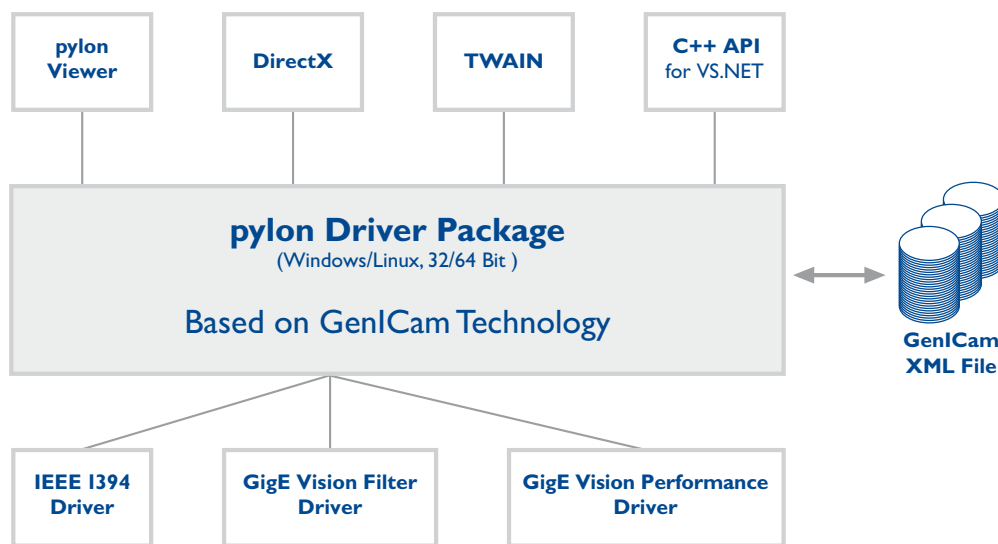

The internal architecture of the pylon driver package is based on GenICam Technology, which offers you easy access to the newest camera models and the latest features. Changes to an existing camera device in your application essentially become a plug-and-play process.

The pylon GigE Vision Performance Driver quickly separates incoming packets carrying image data from other traffic on the network and makes the data available for use by your vision application while requiring the lowest CPU resources. This driver can only be used with network cards that include specific Intel chipsets. The pylon GigE Vision Filter driver supports all kinds of

hardware, common GigE network cards, and GigE ports on your motherboard as well. The pylon IEEE 1394b driver gives you access to a well-established interface technology, but with double the bandwidth offered in the past. And by using the newest driver stack technology, Basler raises the quality of this service above the Microsoft standard.

The pylon Viewer offers you a convenient application for testing and evaluating Basler cameras. The new tree oriented design and the different levels of user access let you quickly and easily determine the best camera settings for your application.

Basler scout2 Series – Cost-Effective GigE Cameras with a 100 Meter Cable Length and Power over Ethernet (PoE)

The scout2 series is the next generation of Basler's successful scout series. It offers a broad spectrum of Sony CCD sensors in a variety of resolutions and speeds. The scout2 addresses applications that are extremely price sensitive and makes a convincing argument with its excellent price/performance ratio.

In contrast to our competitor's cameras, the scout2 is a second generation camera family and benefits from Basler's extensive experience designing and building our successful series of scout GigE cameras. As the pioneering GigE company, Basler has always kept our GigE interface technology a step ahead of the competition. With the Basler scout2, you get our bundled experience in GigE Vision, which lets you take the full advantage of our leading edge technology. And the new Power over Ethernet functionality that allows a single cable connection between the Basler scout2 and a PC makes using a GigE camera even more convenient.

The Basler scout2 family features a GenICam compliant API and uses our latest drivers. Along with the drivers, a GUI based software application is provided that lets users easily set camera parameters, adjust image quality, and control cameras from a remote computer.

Your benefits from the Basler scout2 family include:

- Resolutions from VGA to 2 megapixels with up to 120 fps
- A Gigabit Ethernet interface with Power over Ethernet (PoE)
- 100 meter cable lengths provided by Gigabit Ethernet
- Enhanced color features for better color fidelity and color separation
- Up to 12 bit depth and no bandwidth limitations on 8 bit data flow inside the camera
- Free Gigabit Ethernet drivers

Basler scout2 cameras are a perfect fit for a wide variety of vision applications including semiconductor and component inspection, manufacturing quality control, food and beverage inspection, intelligent traffic systems, microscopy and medical imaging, biometrics, and many others

Enhanced Color Features

Basler scout2 color models include a novel color image processing concept with enhanced color features. These features let you make easy, detailed color adjustments to achieve very realistic color reproduction. This makes scout2 cameras an ideal fit for color applications.



Outstanding Image Quality

The scout2 family is equipped with an assortment of Sony CCD sensors in mono and color. These sensors were selected to provide outstanding image quality in combination with the scout2 readout and processing electronics. For precise imaging results, all scout cameras run in progressive scan mode.

Gigabit Ethernet (GigE Vision) Drivers

Basler provides its own Gigabit Ethernet drivers for the scout2 camera family. These drivers are compliant with the GigE Vision standard and are optimized for the scout2 family. They have been used in several thousand installations since 2006 and are well known for their stability and ease of use. To give you maximum flexibility, Basler provides two different drivers, the filter driver and the performance driver.

The filter driver quickly separates incoming packets carrying image data from other traffic on the network and makes the data available for vision applications running on the computer.

The performance driver can support the most demanding applications with multiple cameras, high data rates, or very strict real-time requirements. When the performance driver is used in combination with a dedicated network interface card (Intel), the load on the host computer's CPU is significantly reduced.

What Makes Basler Camera Quality So Special?

How Does Basler Measure and Define Image Quality?



To ensure consistently high product quality, we employ several quality inspection procedures during manufacturing. The following list describes some of the most essential actions we take to meet your highest requirements:

- The back focal length on each camera is carefully measured and adjusted. This guarantees an optimum distance between the lens flange and the sensor and ensures compliance with optics standards.
- Our advanced Camera Test Tool (CTT+), the first fully-automated inspection system for digital cameras, checks all of the significant quality aspects of each camera we produce. The CTT+ is a unique combination of optics, hardware, and software that can be quickly and efficiently used to calibrate a camera and to measure its performance against a set of standards. For defined sets of conditions, an automated software program examines the camera's output, makes any calibration adjustments necessary, and compares the output to a strictly defined set of performance criteria.



Basler is leading the effort to standardize image quality and sensitivity measurement for machine vision cameras and sensors. All measurements done by Basler will be in 100% compliance with the new European Machine Vision Association EMVA 1288 standard. Because it describes a unified way to measure, compute, and present the specification parameters for cameras and image sensors used in machine vision applications, Basler is giving the EMVA 1288 standard our strongest support.

The aviator family will be characterized and measured to provide information about the quality and sensitivity of our products. All data can be found on Basler's website: www.baslerweb.com

RoHS Compliance

The Basler scout2 series is RoHS compliant. This is especially important in applications where the end-user requires strict RoHS compliance in all system components.



www.baslerweb.com

Germany, Headquarters
Phone +49 4102 463 500
Fax +49 4102 463 599
bc.sales.europe@baslerweb.com

USA
Phone +1 610 280 0171
Fax +1 610 280 7608
bc.sales.usa@baslerweb.com

Japan
Phone +81 45 227 6210
Fax +81 45 227 6220
bc.sales.japan@baslerweb.com

Singapore
Phone +65 6425 0472
Fax +65 6425 0473
bc.sales.asia@baslerweb.com

Korea
Phone +82 707 1363 114
Fax +82 707 0162 705
bc.sales.korea@baslerweb.com